

# Rollei 35

posted 1-17-'04

This camera manual library is for reference and historical purposes, all rights reserved.

This page is copyright by [mike@butkus.org](mailto:mike@butkus.org), M. Butkus, N.J.

This page may not be sold or distributed without the expressed permission of the producer  
I have no connection with Chinon Co., Japan

**If you find this manual useful, how about a donation of \$3 to:**

**M. Butkus, 29 Lake Ave., High Bridge, NJ 08829-1701**

**Most other places would charge you \$7.50 for a electronic copy  
or \$18.00 for a hard to read Xerox copy.**

**This will help me to continue to host this site, buy new manuals, and pay their shipping costs.**

**It'll make you feel better, won't it? If you use Pay Pal, use the link below.**

**Use the above address for a check, M.O. or cash.**

[Back to my main Chinon page](#)

---

## Rollei 35

## Rollei 35



[www.butkus.org](http://www.butkus.org)

in der Praxis

in practical use

---

## The Rollei 35

The Rollei 35 is a special camera - the camera for you. It is designed for your pleasure!

That is why we have designed this camera to be so compact and handy - you can always carry it in your pocket. We have fitted it with a cadmium supplied exposure meter system for quick and reliable shooting. And with the 40 mm Carl Zeiss Tessar f/3.5 we not only selected a world famous lens, but also the ideal focal length for you: with the 57° angle of view you take in a more generous field of view than with a normal miniature camera lens. To let you get on with picture taking straight away, here is a brief instruction summary. So just read up to page 11 - and you can start shooting.

With best wishes for good shooting and fresh fun every day with your Rollei 35 - from  
Rollei-Werke Franke & Heidecke

### Quick Guide to Important Points

	Page
The Rollei 35	5
Get to Know the Rollei 35	7
Loading the Camera	9
Shooting	11
Unloading the Film	13
Practical Notes:	13
j) Film Transport	
2 Is the Camera Loaded?	13
3 Setting the Film Type Indicator	13
4 Selecting the Shutter Speed	15
5 Time Exposures	15
6 Depth of Field	15
7 Pre-selecting Apertures	17
8 Correct Exposure	17
9 Changing the Battery	19
10 Flash Shots	19
11 Exposures with Filters	21
12 Shooting with the Lens Hood	21
13 The Wrist Strap and Leather Case	23
13 Taking Care of the Rollei 35	23

This manual was created by M.  
Butkus, [www.butkus.org/chinon](http://www.butkus.org/chinon)

---

---

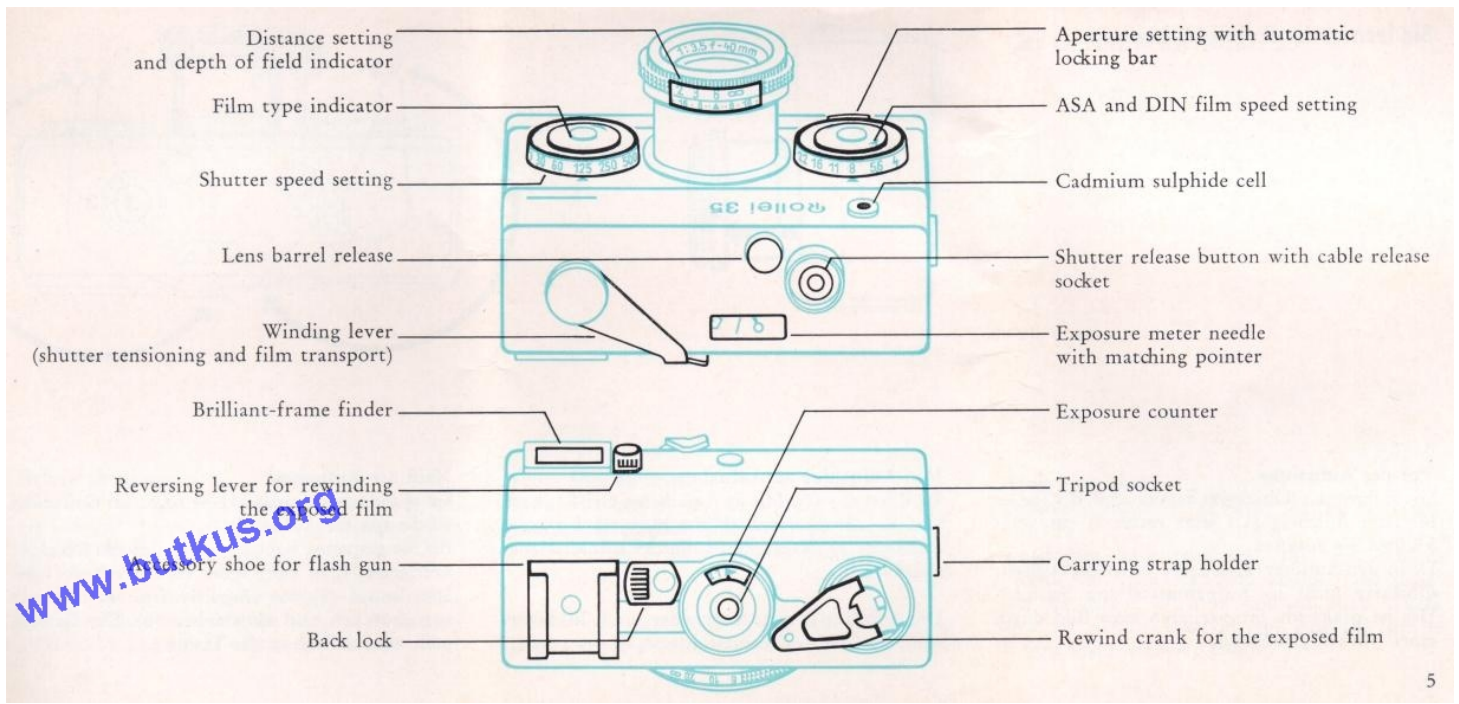

This manual scanned by M. Butkus  
[www.butkus.org/chinon](http://www.butkus.org/chinon)

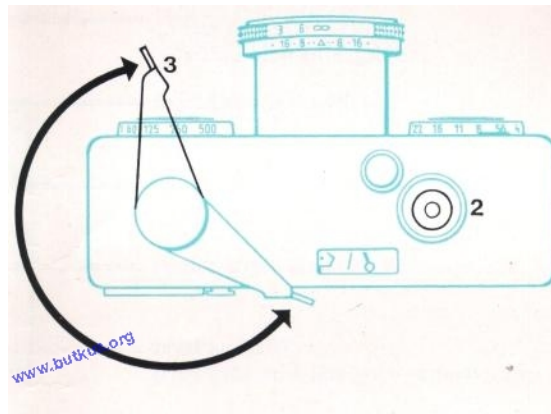
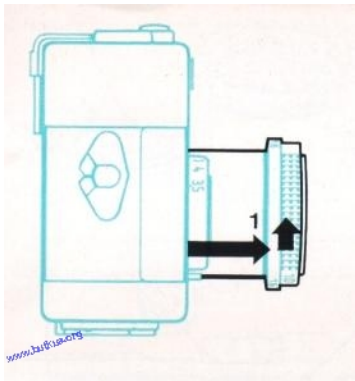

### Before Shooting

Pull out the lens and turn it as far as it will go towards the stop (1) until it engages. Now you can shoot. The shutter release button (2) is locked as long as the lens is not in shooting position. This handy safety measure stops you from wasting pictures by premature exposure.

### From Shot to Shot

Press the release (2). Then fully pull out the winding lever (film transport) as far as it will go (3). So the Rollei 35 is immediately ready to shoot again.

Double exposures, blank frames and overlapping frames are impossible.

### After Each Shot

Tension again (4) to be ready for the next shot.

Until you have tensioned, the lens remains locked. Only then can you unlock it by pressing the button (5); now you can turn it back and push it into the body (6). And the camera is slim again for your pocket.

This manual taken from [www.butkus.org/chinon](http://www.butkus.org/chinon)

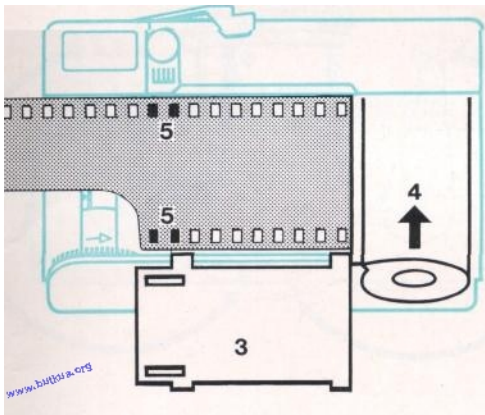
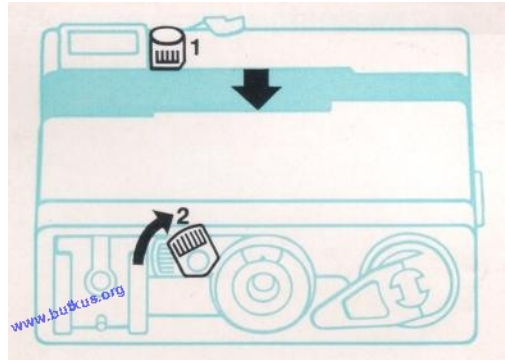
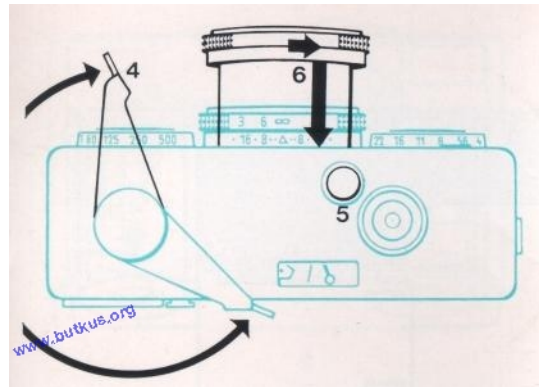

## Loading the Camera

### Inserting the Film

Turn down the lever (1).

Unlock the back (2) and pull it off.

Swing open the pressure plate (3).

Push in the cartridge (4) and pull out the film until both perforated edges engage the sprocket teeth (5). Then swing the pressure plate (3) over the film and hold it down.

Push the film leader fully through the slot (6) and wind it up on the take-up-spool by turning the flange (7) in the direction of the arrow as long as it can be turned.

Swing the latch open to its stop (2), push the camera back in place and lock it. Check that the back is firmly secured.

### Setting the Film Speed

To ensure correct exposure readings turn the black disc (8) by its milled rim to set the index to the ASA or DIN rating shown on the film packing.

### Advancing the Film to Frame No. 1

Pull out the lens (9) and turn it as far as it will go to engage.

Alternately release (10) and tension by pulling the lever to its stop (11) until after tensioning the exposure counter (12) indicates No. 1. Now the Rollei 35 is ready to shoot.

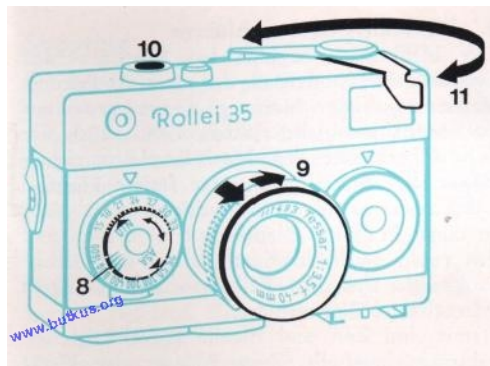
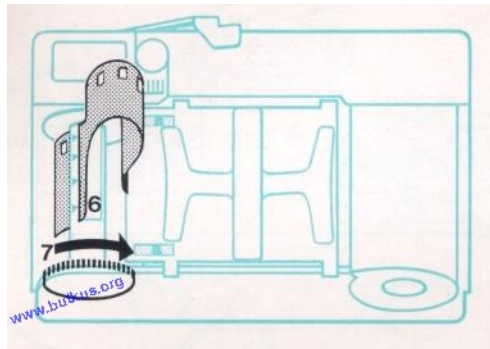

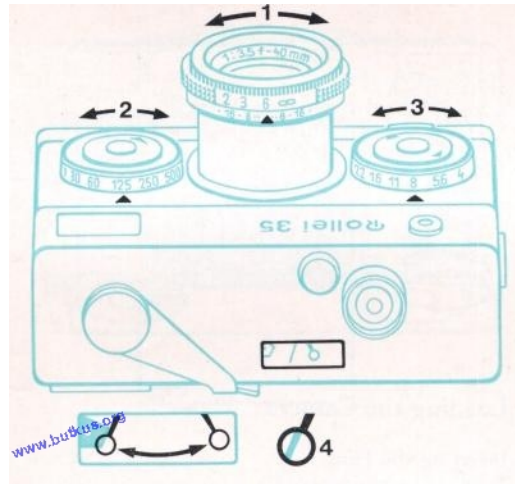
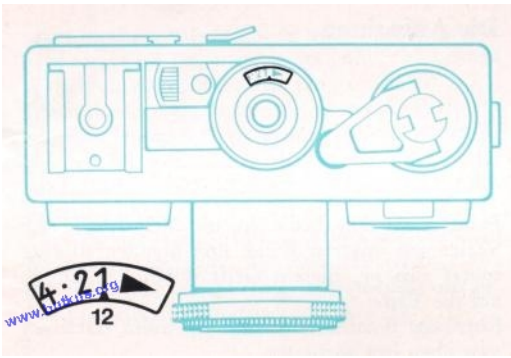

## Shooting

Set the controls by pressing the index finger against the lower edge of the setting wheels or rings. This also releases the aperture wheel by pressing on the ledge underneath. All settings are read off against the triangular index mark at the top.

### 1. Set the Distance

Turn the lens mount by its lower edge (1) to set the required distance to the index mark. See also Note ⑥. The same scale underneath the lens rim carries distances in meters.

### 2. Pre-select the Exposure Time

Turn the shutter speed wheel (2) to engage the selected exposure time opposite the index mark. For instantaneous exposures see Note ⑥. For time exposures see Note (3). The measuring range starts where the meter needle becomes visible outside the red area.

### 3. Line up the Matching Pointer

For reliable readings point the camera accurately at the subject, so that the exposure meter takes in the correct field of view. For shots out of doors with large sky areas point the camera, slightly downwards rather than upwards. With the camera held in this way: Turn the aperture wheel (3) to bring the red matching pointer (4) into line with the exposure meter needle. If necessary select a longer or shorter exposure time.

The shutter speed and aperture are now set for correct exposure. To check the settings you can lower the camera from its shooting position. For pre-selecting apertures see Note Q7 .

#### 4. Releasing

Hold the eye behind the finder eyepiece, sight the subject in the brilliant frame and press the shutter release button (5).

To get the camera ready for the next shot pull the winding lever (6) out as far as it will go with your thumb. (See Note (D).) The exposure counter shows the number of the next shot. If the winding lever is locked, this signifies that the camera is ready for shooting. Now you can release the lens by pressing the button (7), and turn and push it back into the body.

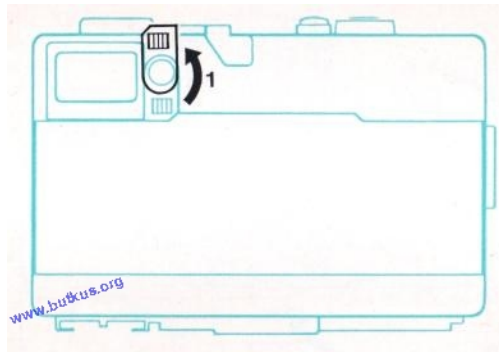
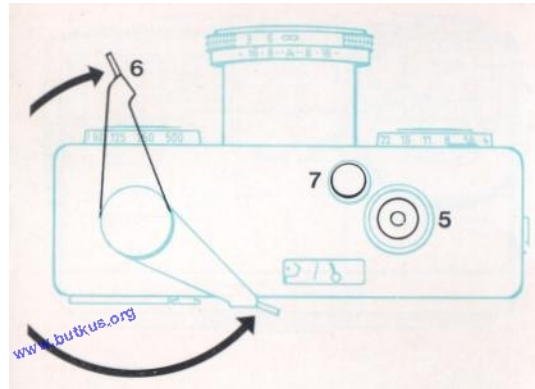

#### Unloading the Film

After the last picture (depending on the film length frame 36, 20 or 12) the film has to be rewound:

Turn the lever (1) upwards.

Unfold the crank (2) and turn in the direction of the arrow until the resistance of pulling the film disappears.

Fold up the crank again and turn down the lever (1).

Unlock and remove the camera back, take out the cartridge and preferably repack it light tight in its original packing. Get color films processed as soon as possible.

Never change film in direct sunlight! Utilize, at least, the shadow of your own body!

## Practical Notes

- Film Transport

You can operate the transport lever either in one swing or in two short swings until it locks - whichever you prefer.

- Is the Camera Loaded?

If you are not sure after a long interval, unfold the rewind crank and try turning it gently in the direction of the arrow. If you meet a resistance you know that there is a film in the camera. If the camera is empty, the crank turns freely.

- Setting the Film Type Indicator

To keep a check on the type of film you have in the Rollei 35 turn the black disc by its notches and set the pointer to the film type in use (black and white negative, color negative film, artificial light color film, daylight type color film.)

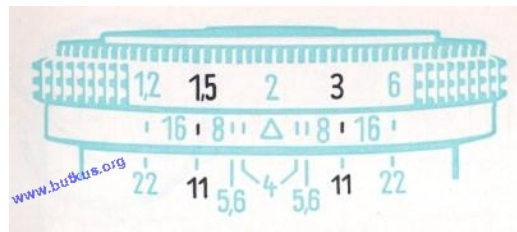
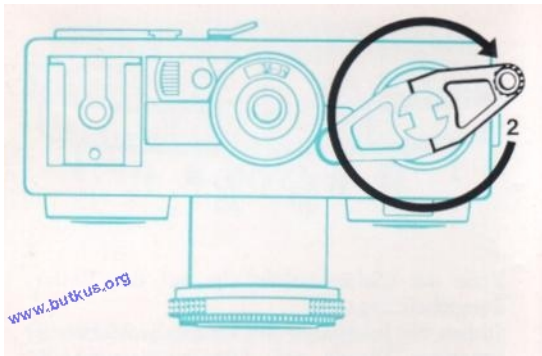

Zeitbelichtung		Automatisch ablaufende Momentzeiten							
B	1/2	1/4	1/8	1/15	1/30	1/60	1/125	1/250	1/500
ruhende Motive (Stativ!)				mäßige Bewegungen			schnelle Bewegungen		

- Selecting the Shutter Speed

The figures 2 to 500 on the shutter speed scale indicate fractions of a second. The speed ring engages at each setting; you cannot set intermediate values. Select a sufficiently fast shutter speed for sharper pictures: Firstly, use fast speeds for hand-held shots to avoid camera shake. Here 1/30 second is the longest permissible time; 1/60 or 1/125 second is safer and more frequently used.

Secondly, use faster shutter speeds for fast moving subjects to avoid movement blur. Thus sports shots need 1/500 second, running children 1/250, fast walking pedestrians 1/125, ambling people 1/60 or - if farther away - 1/30 second.



As a rule, the farther away the moving subject, the sharper it will appear. The risk of movement blur is also reduced by shooting in the direction of the movement (rather than across it).

- Time Exposures

The B setting on the shutter speed wheel provides time exposures of any required length. Keep the release button depressed for the required exposure time. The shutter closes when you let go again.

With time exposures you can also take shots in very poor light which is too weak for an exposure meter reading. As a special case, if you arrive at the B setting by lining up the matching pointer, the correct exposure time is 1 second (double the next exposure setting). For long time exposures place the camera on firm support or a tripod and use a cable release with time lock.

- Depth of Field

The image of a subject is sufficiently sharp over a range of distances in front of and behind the focused distance. This depth of field zone shown on the distance scale: Look up the index line of the aperture in us to each side of the focusing index. The distant figures on the focusing scale opposite these lines then indicate the sharply covered subject range.

Depth of field is particularly desirable for candid snapshots, sports photography with rapidly changing subject distances, and for scenes extending in depth. For this reason the most used full snapshot settings of 6 and 20 feet are marked in red on the distance scale. At a medium aperture (f/8 to f/11) these settings provide extended focusing ranges: at 6 feet from about 4 1/3 to 9 feet; at 20 feet from about 10 feet to infinity «.

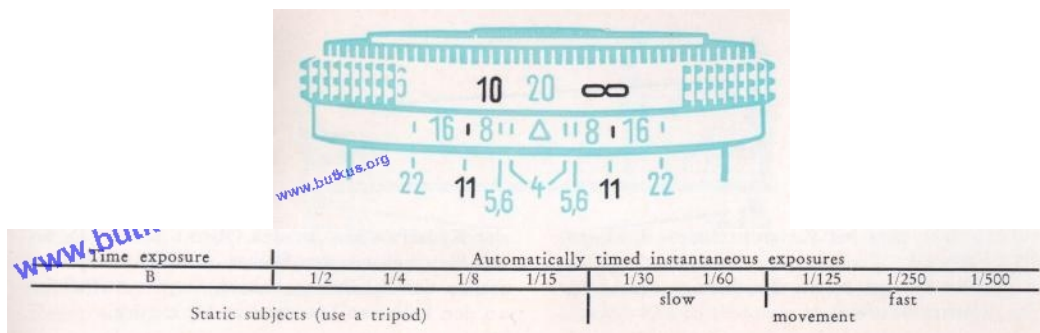

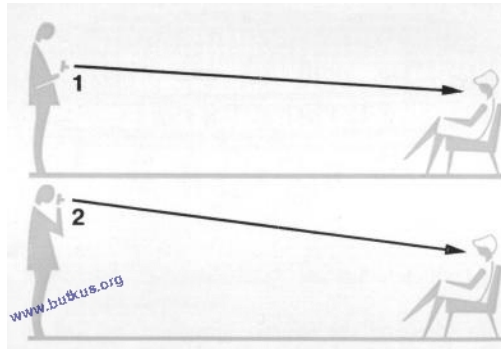

For distant views with near foregrounds set the infinity marking c to the depth of field mark for the aperture in use. That extends the depth of field to the nearest possible point in the foreground.

### Pre-selecting Apertures

According to the type of subject you can line up the matching pointer with the meter needle by turning either the aperture wheel or the shutter speed wheel.

With moving subjects pre-select the exposure time to make sure of a suitably fast shutter speed. Then match up the pointers by turning the aperture wheel.

If on the other hand depth of field is more important, determine the required aperture and pre-select this. Now match up the pointers by turning the shutter speed wheel. If necessary complete the exact matching with the aperture wheel. Selected speed have to be in click-stop position.

In every case the camera must point at the subject while you line up the pointers.

### ® Correct Exposure

As a basic rule, always point the camera while taking exposure readings (1) exactly in the direction of the subject (2). Inadvertent tilting of the camera - for example into the sky while taking landscape views - can falsify the reading and in this case lead to under-exposure.

The exposure meter evaluates the average brightness of the measured subject field. With subjects of average contrast it automatically indicates the correct exposure. But even with shots of considerable brightness range you can take the readings in such a way as to ensure correct exposure for the main subject.

Normal subjects: the view is lit from the front or at an angle from the side. There are no heavy shadows, and dark and bright areas are balanced. (This uniform front lighting also yields the most saturated colours in colour shots.) Result: The measured exposure is correct for the whole field of view. A special case: The main subject contrasts strongly in brightness against the background. For example, with a portrait of a suntanned face against bright clouds an average reading would give too much importance to the sky. Yet it is the head which matters for the exposure. The right way: Take a close-up reading with the camera near the subject (3) until the main object completely fills the finder. After setting the exposure go back for shooting to the previous viewpoint (4).

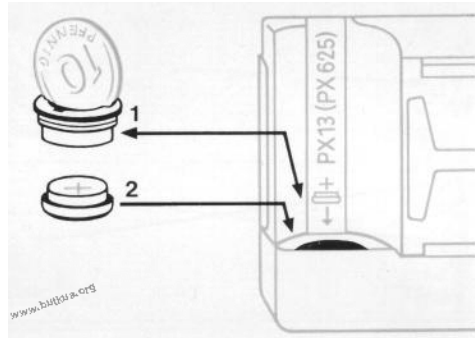
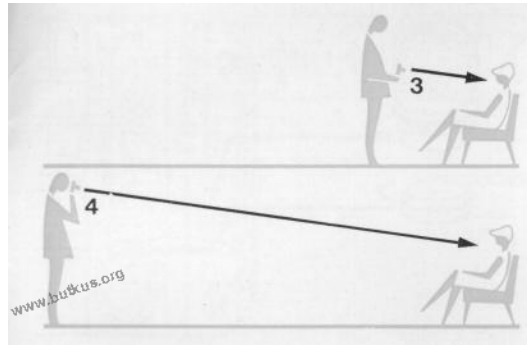

Substitute readings: If a close-up reading is not possible, point the camera at a substitute object of average contrast and under the same lighting. Use the setting obtained for the exposure.

Against the light: When shooting against the light open the lens aperture by one step (next lower f/number).

For colour subjects to be taken on reversal colour film avoid very great brightness differences. A close-up reading of the shadow areas usually leads to excessive exposure for the sunlit image portions, which then appear too light and burnt out when you project the slide. An average brightness reading (as in the normal case) here again yields pictures which correspond most closely to the natural colour impression.

### Changing the Battery

The cadmium sulphide exposure meter is particularly compact and powered by a Mallory battery PX 13. According to the manufacturer, the durability of the battery is 18 to 24 months, provided that the unused camera is kept in the case (i. e. in the dark, the voltage drop occurs suddenly. Symptom: the exposure meter needle does not deflect anymore.)

Recommended precautions: Change battery annually. PX 625 or PX 13. You must use a Wein Air (non mercury) 1.3 V battery. They are available on line. There are RL 9 batteries, but they are 1.5v against the mercury battery 1.3. So you should set the camera ASA just a notch lower to compensate for the higher voltage.

Remove battery if the camera is not used over an extended period.

Always remove and discard exhausted batteries. At very low temperatures (camera cooled to, below  $-10^{\circ}\text{C} = +14^{\circ}\text{F}$ ) change battery to type PX 625.

To change the battery, first open the camera Unscrew the slotted screw cap (1) with a coin Insert the fresh battery into the camera, so that the plus sign + remains visible (2). Replace the screw cap and screw tight with coin.

## 10. Flash Shots

The accessory shoe with central flash outlet takes a flash gun (3).

Flash guns without central contact in the foot require an adapter with an outlet at the side to take the plug-in flash cable. Flash bulbs and electronic flash can be used. For colour shots use only blue bulbs or electronic flash. A standard auto flash will work, they work by adjusting the flash by the built-in electric eye to the ASA set on the FLASH. You then look at the back and see where the auto distance F/stop. Set the camera F/stop to that. You can then shoot within that flash range of that camera. Some flash have multiple flash setting. The smaller the F/stop, the more in focus you will have, but you will have a shorter flash range. If you choose a wider F/stop available on your camera, you can get further from the subject, but your focus better be good or you will have out of focus images. You can set the leaf shutter at 1/125 sec or 1/250 as a leaf shutter has to be fully open at any instant. That's when the flash will go off. Different from a focal plane shutter on most 35mm cameras.

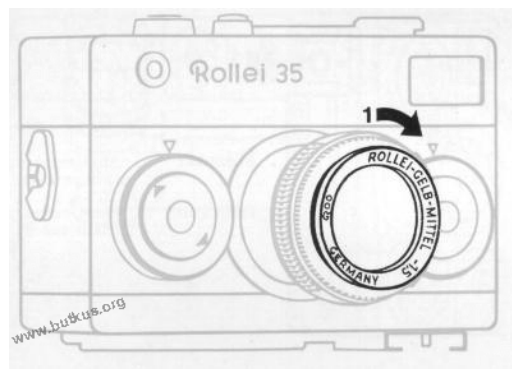
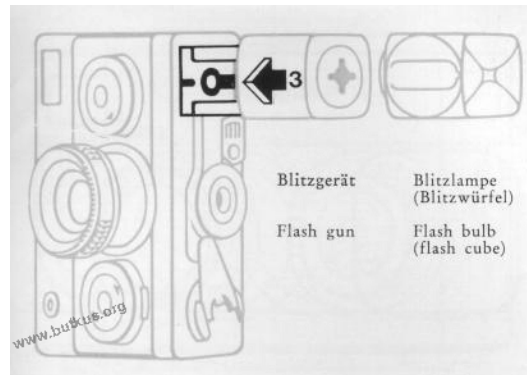

For flash shots ignore the exposure meter. Set the exposure time, aperture and subject distance as recommended by the manufacturer of the flash unit. Use the settings indicated for X contact.

Shadow areas are reduced if the flash gun is situated above the lens and you hold the camera accordingly: keep the flash to the left of the camera for upright shots, and on top for horizontal shots.

The Rolleiflex 35 is easy to operate in both these positions.

### n Exposures with Filters

The thread of the lens mount takes a screw-in filter (1).

Filters require an exposure correction. Its value is engraved on the filter mount. This indicates the number of steps by which the aperture has to be opened (towards lower f/numbers) or the exposure time increased.

Usually the exposure is corrected by opening the aperture. For example if the measured aperture is f/11, and the filter correction value -1.5 (i. e. 1 1/2 aperture steps), use an aperture setting between f/8 and f/5.6. If you want to correct by increasing the exposure time, moving the shutter speed wheel from one value to the next corresponds to a full exposure step correction. Half steps can only be allowed for by intermediate aperture settings.

Rollei filters for black-and-white shots:

Rollei medium yellow filter (exposure correction -1.5). This makes the sky reproduce darker, clouds more brilliant and improve modelling in snow shadows. Rollei orange filter (exposure correction -1. to -3, according to the film type used). This darkens blue skies to give heavy thunderstorm effects and lightens yellows and reds.

Rollei filters for colour shots:

Rollei filter H 1 and Rollei colour conversion filter R 1.5 (these require no exposure correction). They subdue blue casts which can arise on cloudless days through the predominant blue skylight, especially in distant views. With some reversal colour films a warmer overall rendering may be desirable. In that case the R 1.5 filter may be used for all shots.

## 2 Shooting with the Lens Hood

The outer rim of the lens will take the push on Rollei lens hood (2) to protect the lens against direct rays from the sun, as well as against splashes of water and drops of rain. It ensures optimum brilliance and sharpness for your shots. Always use it when shooting into the sun.

This manual taken from [www.butkus.org/chinon](http://www.butkus.org/chinon)

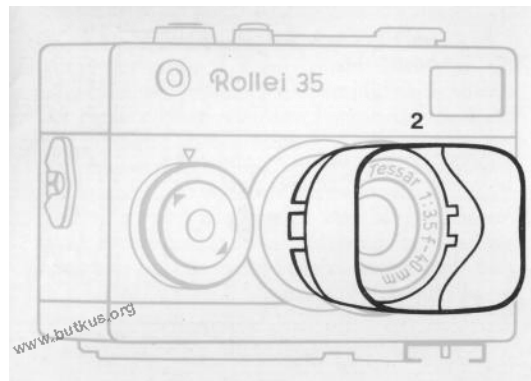

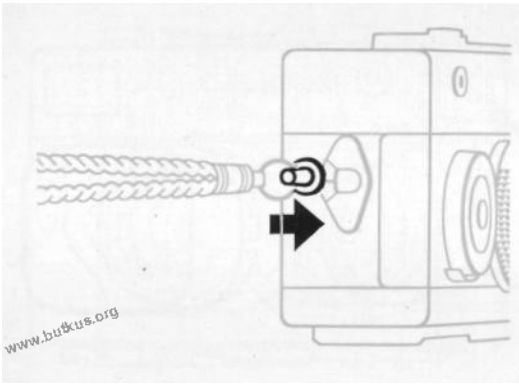

### The Wrist Strap and Leather Case

The wrist strap is fixed to the fitting at the side. Push the protruding retaining spring against the camera body with the button on the strap and push the button home.

To remove, push down the spring leaves with a fingernail and slide off the button. With the strap the camera can hang from the wrist even when it is in its leather case. Simply open the zip fastener of the case and push back the latter. During shooting it simply hangs from the strap.

### Taking Care of the Rollei 35

The Rollei 35 is particularly solidly built for everyday use.

However, protect the camera against hard knocks and don't drop it. As a safety measure wrap the wrist strap around your wrist.

Protect the Rollei 35 against moisture, dust, wind-blown sand at the seaside and continuous exposure to sunlight. This applies especially when the camera is opened while changing films. From time to time clean the inside of the body with a soft brush.

A soft sable brush is also the best means for cleaning the lens. The lens surfaces are sufficiently recessed to reduce the risk of accidental finger marks.

To clean filters, first dust them with a soft brush and then polish with a dust-free chamois leather or a clean handkerchief. If the lens surface mists over in the winter when taking the camera from the cold air outside into the warm air of a room, wait a few moments until the deposit of moisture has evaporated on its own.

And if at any time you have a special technical query - at home or on your travels abroad - remember that the international Rollei Service is always at your disposal for advice and information.